

MALE END VIEW

(LONG)

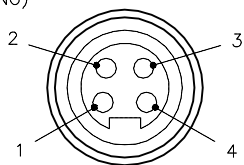

SPECIFICATIONS

CONTACT CARRIER MATERIAL/COLOR	PVC/NYLON, BLACK
GLAND MATERIAL/COLOR	NYLON/BLACK
CONTACT MATERIAL/PLATING	BRASS or COPPER/GOLD
COUPLING NUT MATERIAL/FINISH	STAINLESS STEEL/PASSIVATED
SEAL MATERIAL/COLOR	NITRILE/BLACK
RATED CURRENT [A]	UP TO 35.0 A
RATED VOLTAGE [V]	600 V
MAXIMUM WIRE SIZE	8 AWG
TERMINATION METHOD	SCREW TERMINAL
TEMPERATURE RATING	-40°C to +90°C (-40°F to +194°F)
PROTECTION CLASS	IP 67/NEMA 6P
CABLE GRIP RANGE	9.0mm [0.35"] to 26.0mm [1.02"]

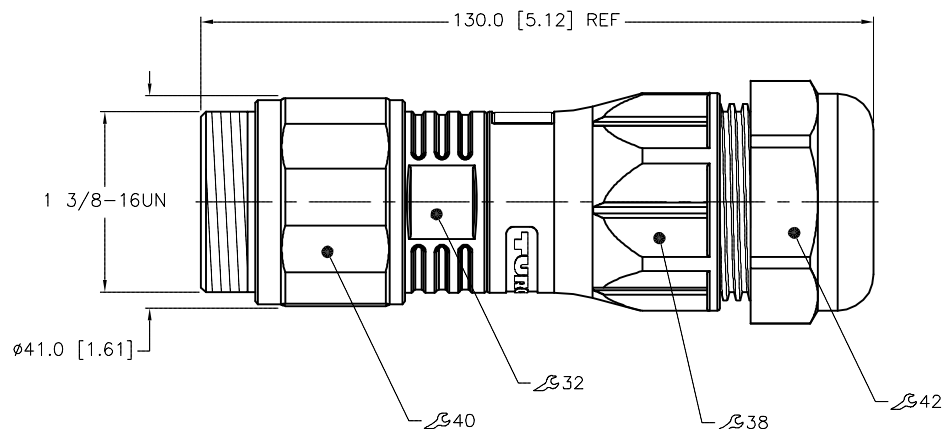
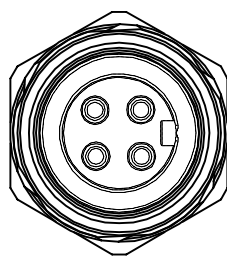

WIRE SIDE VIEW OF CONTACT HOLDER TO SHOW LABEL DETAILS

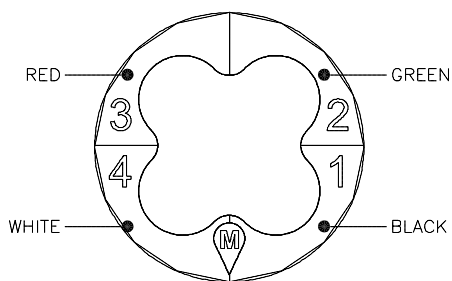

(SCALE 2:1)

**CAUTION:**  
RISK OF ELECTRICAL SHOCK  
DO NOT DISCONNECT UNDER LOAD

RELATED DOCUMENTS 1. 2. 3. 4.	3RD ANGLE PROJECTION 	THIS DRAWING IS CONFIDENTIAL AND THE PROPERTY OF TURCK INC. USE OF THIS DOCUMENT WITHOUT WRITTEN PERMISSION IS PROHIBITED.		3000 CAMPUS DRIVE MINNEAPOLIS, MN 55441 1-800-544-7769 (763) 553-7300 (763) 553-0708 fax www.turck.us	
	MATERIAL  SEE SPECIFICATIONS	DRFT RWC APVD	DATE 09/10/09 SCALE 1=1.5	DESCRIPTION <b>TURCK</b> GSDV 40-0	
FINISH  SEE SPECIFICATIONS	ALL DIMENSIONS DISPLAYED ON THIS DRAWING ARE FOR REFERENCE ONLY  CONTACT TURCK FOR MORE INFORMATION	UNIT OF MEASUREMENT <b>MILLIMETER [ INCH ]</b>		IDENTIFICATION NO. U2-16368	REV B
B UPDATED RATED CURRENT	RDS 04/22/20	75819	DO NOT SCALE THIS DRAWING		
REV DESCRIPTION	BY DATE	ECO NO.	FILE: U2-16368	SHEET 1 OF 1	